

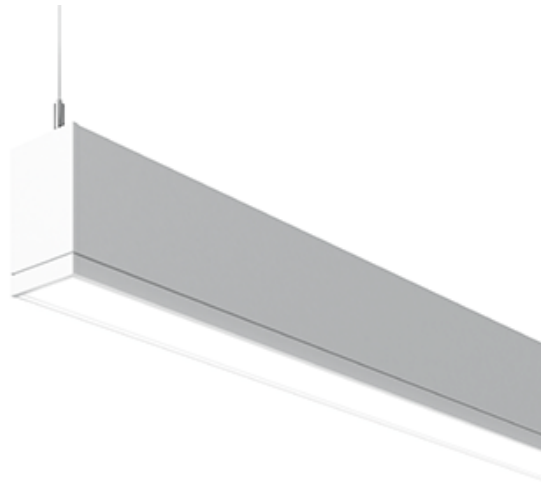

Linear

TruGroove Suspended LED

Direct/Indirect
CRI >80 3000K, 5200 lm/4ft



Project: _____
 Spec Type: _____
 Catalog No: 2906LCBWW
 Qty: _____
 Line Notes: _____

TruGroove LED is driving performance beyond the edge. Innovative optics deliver exceptional uniformity and wide row spacing from a 3” aperture continuous line-of light. An extended family and refined design are perfect for lighting any professional space.

Ordering guide

Product Type	Source	Color Temp *	Lumens *	Lower Optics	Upper Optics	Run Length	Wiring †	Voltage	Driver	Finish
2906	L	C	B	W	W					
TruGroove Suspended Direct/Indirect	L LED	A 4000K B 3500K C 3000K	B 5200 lm/4ft (35/65) C 4600 lm/4ft (30/70) D 3500 lm/4ft (35/65)	Q Symmetric MesoOptics W Asymmetric MesoOptics	Q Symmetric Performance W Asymmetric Performance	04 4' 06 6' 08 8' 22 2x2' XX Total run length (2 increments)	1 1cct 2 2 cct Up/Down 3 1 cct w/ EM cct 5 1 cct w/ BP 7 1 cct w/ Dimming	1 120V 2 277V 3 347V	E Philips Advance Other drivers available - consult factory	W Standard White T Titanium Silver B Black X Custom

* Nominal values within a range. Consult ies file for exact color temp, lumens and up/down distribution † Consult website for complete list of standard wiring options

Mounting Hardware

Mount Type
Consult separate mounting spec sheet for mount type options

Suspension Length
Distance from ceiling to top of luminaire in inches

Endcaps - Flat Grooved

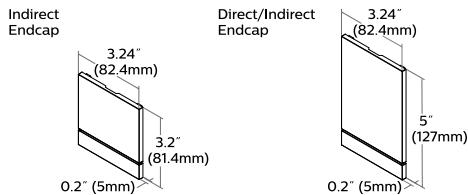

Integrated Controls Please indicate with check mark.

- Response Daylight Sensor Single Zone (DS)
- Philips Actilume Occupancy Sensor (DO) (includes field commissionable daylight sensor)

TruGroove Suspended Direct/Indirect LED

CRI >80 3000K, 5200 lm/4ft

Housing

Precision aluminum extrusion, post painted.

Weight

Maximum: Suspended & Surface 3.9lb/ft, Wall 4.1lb/ft & 2'x2' Corner unit 21lb

Optical System

Upper hemisphere: White light emitted from a linear array of upward-facing LEDs is shaped into a homogeneous, wide-throw batwing distribution using either a freeform elliptical lens or an engineered light guide panel.

Lower hemisphere: White light emitted from a linear array of downward-facing LEDs is laterally redirected using either a biconvex lens or optical microstructures embedded in a layer of MesoOptics DX film. An extruded acrylic lens and MesoOptics film assembly then generate an optimal batwing distribution and a uniform continuum of light.

Standard Driver

Dimming: 0-10V - 5-100%. Output is Class 2 rated.

Electrical

Factory pre-wired to section ends with quick-wire connectors.

Mounting

Suspended: Variable sling mount allows +/- 5" of horizontal adjustment from joint or end. Aircraft cable and tamper-resistant gripper provide unlimited vertical adjustment. Aircraft cable, crimp and gripper are independently tested to meet stringent safety requirements.

Wall: Hidden steel mounting brackets are provided for attachment to existing structure and hold housings close to the wall. Mounts are variable positioning, but should be no more than 4-1/2ft on center and within 12" of an end or joint.

Surface: Fixture is mounted flush to surface using hidden brackets. Brackets attach to existing structure, variable within 0.6"-1.7" of end or joint.

Joints

Self-aligning joining system with hands-free pre-joining wire access.

Endcaps

Diecast flat aluminum endcaps with integral groove to match housing.

Finish

High quality powder coated, available in matte white, black or titanium silver. Other custom colors available on request.

Approvals

Certified to UL, CSA and IES standards.

Lumen Maintenance

At an ambient temperature of 25°C, the LED lumen maintenance expectation is:

L80 (12k) >60,000h according to IES TM-21-11 Addendum A Reported methodology

L80 (6k) 110,000h according to IES TM-21-11 Projected methodology

Warranty

Philips indoor professional luminaires 5 year LED warranty:

<http://www.philips.com/warranties>

Environment

Rated for dry or damp locations in operating ambient temperatures 0-40°C (32-104°F). Certain luminaire components may be adversely affected by contaminants. Damage caused by sulfur, chlorine, petroleum based solutions or other contaminants are not covered under warranty.

Due to continuing product improvements, Philips Ledalite reserves the right to change the specifications without notice.

Options and Details

Cross Section

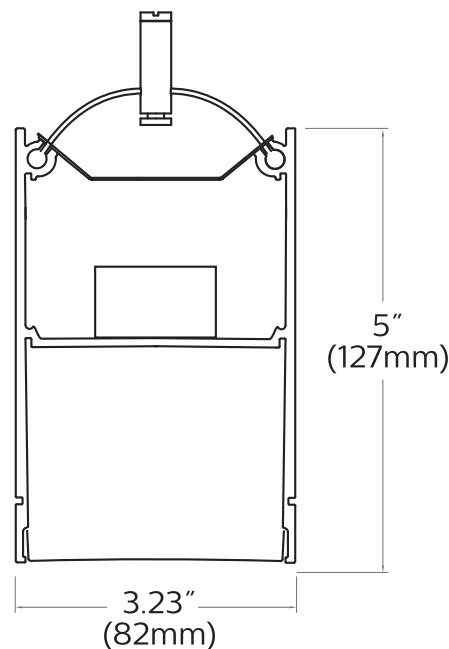

Modules

Suspended Linear Modules Without Endcaps - Side View

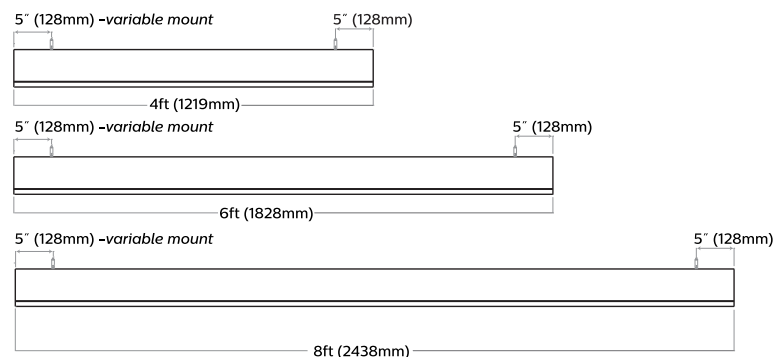

Suspended 2'x2' Corners Without Endcaps - Top View

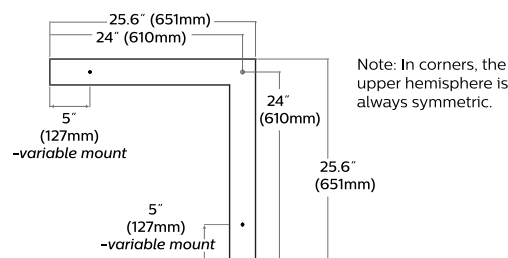

TruGroove Suspended Direct/Indirect LED

CRI >80 3000K, 5200 lm/4ft

Photometry

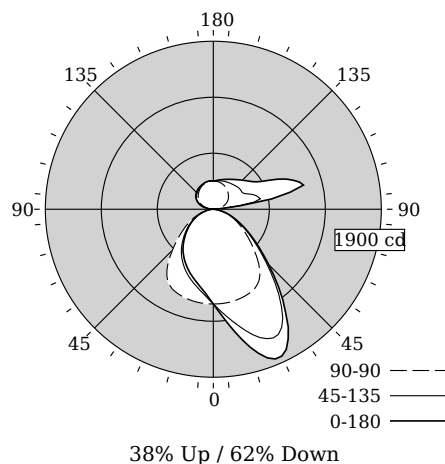

Total Output	4612 lm
Efficacy	92.1 lm/W
CCT	3108K
CRI	81
R9	3
Distribution	38% Up / 62% Down
Spacing Criteria (0/90/180°)	1.66/1.34/0.92
Meets RP-1-04 recommendations for VDT-Normal spaces	

Values per 4ft unit

Fixture photometry has been conducted by an NVLAP accredited testing laboratory in accordance with IESNA LM-79-08

Lumen maintenance of the LEDs has been tested by the manufacturer in accordance with IESNA LM-80-08

IES files for this and other photometric options can be downloaded online at www.lightingproducts.philips.com

Candela Distribution

Vertical Angle	Horizontal Angle					Zonal Lumens
	0	45	90	135	180	
0	1071	1071	1071	1071	1071	0
5	1220	1174	1071	986	960	104
15	1617	1423	1058	864	823	324
25	1833	1606	1026	753	711	532
35	1425	1344	917	629	596	605
45	886	840	653	484	460	513
55	522	498	423	351	336	382
65	288	282	260	229	220	255
75	131	127	120	116	114	130
85	24	22	24	26	28	31
90	0	0	0	0	0	0
95	102	89	31	46	33	97
105	1056	529	103	144	122	342
115	805	414	164	201	193	319
125	544	377	207	236	242	273
135	465	368	240	259	270	239
145	411	353	270	282	289	197
155	373	343	295	304	304	148
165	346	332	311	318	318	92
175	325	321	318	321	323	31
180	318	318	318	318	318	0

Coefficients of Utilization (%)

RCR	Ceiling					Wall					0
	70	50	30	10	70	50	30	50	30	10	
0	110	110	110	110	103	103	103	90	90	90	62
1	101	97	93	90	95	91	88	80	78	75	54
2	93	85	79	74	87	80	75	71	67	63	46
3	85	76	68	63	79	71	65	63	58	54	40
4	78	67	60	54	73	64	57	56	51	47	34
5	72	60	52	46	67	57	50	51	45	41	30
6	66	54	46	41	62	51	44	46	40	36	27
7	61	49	41	36	58	47	39	42	36	32	24
8	57	45	37	32	54	43	36	38	32	28	21
9	53	41	34	29	50	39	32	35	29	25	19
10	50	38	31	26	47	36	29	32	27	23	18

Avg. Luminance (cd/m2)

Vertical Angle	Horizontal Angle		
	0	90	180
55	9770	7931	6295
65	7323	6603	5604
75	5435	4982	4712
85	2959	2959	3502

Electrical Specifications

Input Voltage	120V	277V
Input Power	50.1W	49.1W
Input Current	0.42A	0.18A
Power Factor	0.992	0.963
Total Harm. Distortion	7%	13.1%
Tested values – contact technical support for rated values. Off-state power zero unless certain controls are specified.		

© 2015 Koninklijke Philips N.V. All rights reserved. Philips reserves the right to make changes in specifications and/or to discontinue any product at any time without notice or obligation and will not be liable for any consequences resulting from the use of this publication. philips.com/luminaires
www.philips.com/luminaires



Philips Lighting, North America Corporation
200 Franklin Square Drive, Somerset, NJ 08873
Tel. 855-486-2216

Imported by: Philips Lighting,
A division of Philips Electronics Ltd.
281 Hillmount Rd, Markham, ON, Canada L6C 2S3
Tel. 800-668-9008