

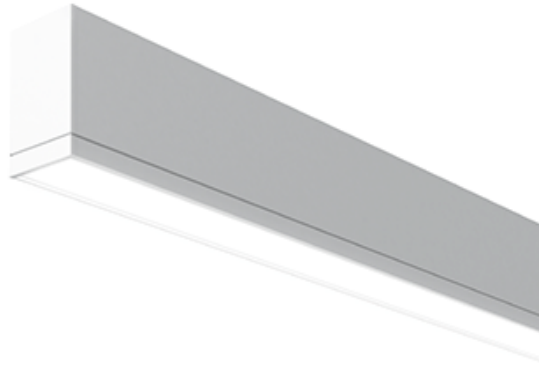

# Linear

## TruGroove Surface LED

Direct  
CRI >80 3000K, 1500 lm/4ft



Project: \_\_\_\_\_  
 Spec Type: \_\_\_\_\_  
 Catalog No: 2911LCKQN  
 Qty: \_\_\_\_\_  
 Line Notes: \_\_\_\_\_

TruGroove LED is driving performance beyond the edge. Innovative optics deliver exceptional uniformity and wide row spacing from a 3” aperture continuous line-of light. An extended family and refined design are perfect for lighting any professional space.

### Ordering guide

Product Type	Source	Color Temp *	Lumens *	Lower Optics	Upper Optics	Run Length	Wiring †	Voltage	Driver	Finish
2911	L	C	K	Q	N					
TruGroove Surface Direct	L LED	A 4000K B 3500K C 3000K	E 3200 lm/4ft G 2300 lm/4ft K 1500 lm/4ft	Q Symmetric MesoOptics W Asymmetric MesoOptics	N None	04 4' 06 6' 08 8' XX Total run length (2' increments)	1 1cct 3 1cct w/ EM cct 7 1cct w/ Dimming	1 120V 2 277V 3 347V	E Philips Advance  Other drivers available - consult factory	W Standard White T Titanium Silver B Black X Custom

\* Nominal values within a range. Consult ies file for exact color temp, lumens and up/down distribution † Consult website for complete list of standard wiring options

### Mounting Hardware

Surface  Mount Type  
 Consult separate mounting spec sheet for mount type options

### Endcaps - Flat Grooved

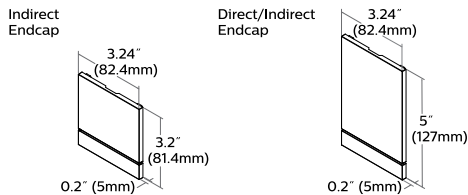

### Integrated Controls Please indicate with check mark.

- Response Daylight Sensor Single Zone (DS)
- Philips Actilume Occupancy Sensor (DO) (includes field commissionable daylight sensor)

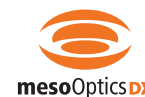

# TruGroove Surface Direct LED

CRI >80 3000K, 1500 lm/4ft

## Housing

Precision aluminum extrusion, post painted.

## Weight

Maximum: Suspended & Surface 3.9lb/ft, Wall 4.1lb/ft & 2'x2' Corner unit 21lb

## Optical System

**Upper hemisphere:** White light emitted from a linear array of upward-facing LEDs is shaped into a homogeneous, wide-throw batwing distribution using either a freeform elliptical lens or an engineered light guide panel.

**Lower hemisphere:** White light emitted from a linear array of downward-facing LEDs is laterally redirected using either a biconvex lens or optical microstructures embedded in a layer of MesoOptics DX film. An extruded acrylic lens and MesoOptics film assembly then generate an optimal batwing distribution and a uniform continuum of light.

## Standard Driver

Dimming: 0-10V - 5-100%. Output is Class 2 rated.

## Electrical

Factory pre-wired to section ends with quick-wire connectors.

## Mounting

**Suspended:** Variable sling mount allows +/- 5" of horizontal adjustment from joint or end. Aircraft cable and tamper-resistant gripper provide unlimited vertical adjustment. Aircraft cable, crimp and gripper are independently tested to meet stringent safety requirements.

**Wall:** Hidden steel mounting brackets are provided for attachment to existing structure and hold housings close to the wall. Mounts are variable positioning, but should be no more than 4-1/2ft on center and within 12" of an end or joint.

**Surface:** Fixture is mounted flush to surface using hidden brackets. Brackets attach to existing structure, variable within 0.6"-1.7" of end or joint.

## Joints

Self-aligning joining system with hands-free pre-joining wire access.

## Endcaps

Diecast flat aluminum endcaps with integral groove to match housing.

## Finish

High quality powder coated, available in matte white, black or titanium silver. Other custom colors available on request.

## Approvals

Certified to UL, CSA and IES standards.

## Lumen Maintenance

At an ambient temperature of 25°C, the LED lumen maintenance expectation is:

L80 (12k) >60,000h according to IES TM-21-11

Addendum A Reported methodology

L80 (6k) 110,000h according to IES TM-21-11 Projected methodology

## Warranty

Philips indoor professional luminaires 5 year LED warranty:

<http://www.philips.com/warranties>

## Environment

Rated for dry or damp locations in operating ambient temperatures 0-40°C (32-104°F). Certain luminaire components may be adversely affected by contaminants. Damage caused by sulfur, chlorine, petroleum based solutions or other contaminants are not covered under warranty.

Due to continuing product improvements, Philips Ledalite reserves the right to change the specifications without notice.

## Options and Details

### Cross Section

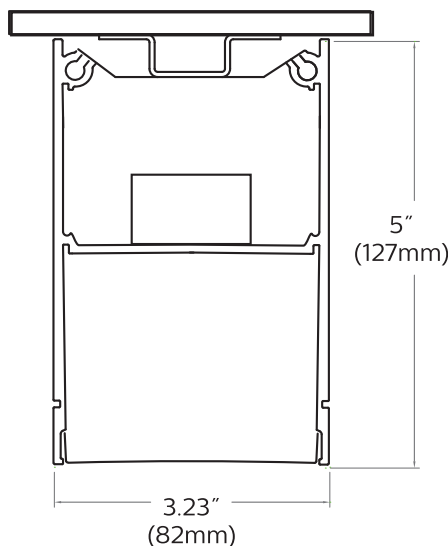

### Modules

#### Surface Mount Without Endcaps - Side View

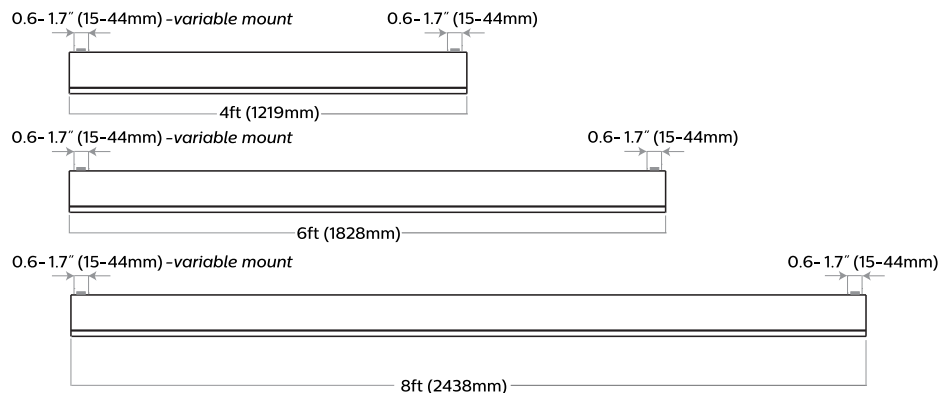

# TruGroove Surface Direct LED

CRI >80 3000K, 1500 lm/4ft

## Photometry

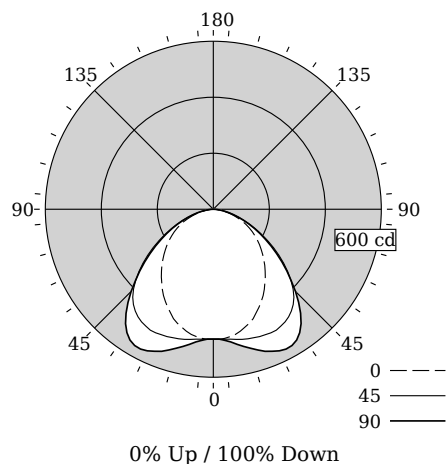

Total Output	1444 lm
Efficacy	95.6 lm/W
CCT	3099K
CRI	81
R9	4
Distribution	0% Up / 100% Down
Spacing Criteria (0/90/180°)	1.15/1.63/NA
Meets RP-1-04 recommendations for VDT-Intensive spaces	

Values per 4ft unit

Fixture photometry has been conducted by an NVLAP accredited testing laboratory in accordance with IESNA LM-79-08

Lumen maintenance of the LEDs has been tested by the manufacturer in accordance with IESNA LM-80-08

IES files for this and other photometric options can be downloaded online at [www.lightingproducts.philips.com](http://www.lightingproducts.philips.com)

## Candela Distribution

Vertical Angle	Horizontal Angle					Zonal Lumens
	0	22.5	45	67.5	90	
0	464	464	464	464	464	0
5	463	463	466	470	470	45
15	436	447	479	506	514	135
25	386	416	487	541	558	221
35	321	368	469	529	538	280
45	255	304	403	425	415	282
55	192	227	286	286	276	231
65	129	149	167	168	162	155
75	64	67	76	77	74	77
85	13	13	16	16	16	18
90	0	0	0	0	0	0
95	0	0	0	0	0	0
105	0	0	0	0	0	0
115	0	0	0	0	0	0
125	0	0	0	0	0	0
135	0	0	0	0	0	0
145	0	0	0	0	0	0
155	0	0	0	0	0	0
165	0	0	0	0	0	0
175	0	0	0	0	0	0
180	0	0	0	0	0	0

## Coefficients of Utilization (%)

RCR	Ceiling					Wall					0
	70	50	30	10	70	50	30	10	50	30	
0	119	119	119	119	116	116	116	111	111	111	100
1	109	105	101	97	107	103	99	98	95	92	85
2	100	92	85	80	97	90	84	86	81	77	71
3	91	81	73	67	89	79	72	76	70	65	60
4	83	72	63	57	81	70	62	68	61	55	52
5	77	64	55	49	75	63	55	61	54	48	45
6	71	58	49	43	69	57	48	55	48	42	39
7	66	52	44	38	64	51	43	50	42	37	35
8	61	48	39	33	60	47	39	46	38	33	31
9	57	44	35	30	56	43	35	42	35	30	28
10	53	40	32	27	52	40	32	39	32	27	25

## Avg. Luminance (cd/m2)

Vertical Angle	Horizontal Angle		
	0	45	90
55	3597	5358	5171
65	3280	4246	4119
75	2657	3155	3072
85	1603	1973	1973

**LED lighting facts**  
A Program of the U.S. DOE

Philips Ledalite

---

**Light Output (Lumens)** 1444

**Watts** 15.1

**Lumens per Watt (Efficacy)** 95.6

---

**Color Accuracy** 81  
Color Rendering Index (CRI)

---

**Light Color** 3099 (Bright White)  
Correlated Color Temperature (CCT)

2700K 3000K 4500K 6500K

---

All results are according to IESNA LM-79-2008: Approved Method for the Electrical and Photometric Testing of Solid-State Lighting. The U.S. Department of Energy (DOE) verifies product test data and results.

Visit [www.lightingfacts.com](http://www.lightingfacts.com) for the Label Reference Guide.

Registration Number: F46Z-6FGAJV (3/18/2015)  
Model Number: 29x1xxxQN  
Type: Luminaire - Linear

## Electrical Specifications

Input Voltage	120V	277V
Input Power	15.1W	15.2W
Input Current	0.13A	0.06A
Power Factor	0.996	0.927
Total Harm. Distortion	9.6%	15%
Tested values – contact technical support for rated values. Off-state power zero unless certain controls are specified.		

© 2015 Koninklijke Philips N.V. All rights reserved. Philips reserves the right to make changes in specifications and/or to discontinue any product at any time without notice or obligation and will not be liable for any consequences resulting from the use of this publication. [philips.com/luminaires](http://philips.com/luminaires)  
[www.philips.com/luminaires](http://www.philips.com/luminaires)



Philips Lighting, North America Corporation  
200 Franklin Square Drive, Somerset, NJ 08873  
Tel. 855-486-2216

Imported by: Philips Lighting,  
A division of Philips Electronics Ltd.  
281 Hillmount Rd, Markham, ON, Canada L6C 2S3  
Tel. 800-668-9008