

System Overview

These instructions review how to install MicroSquare gen 2 wall fixtures. MicroSquare 4ft, 6ft and 8ft modules can be installed as individual standalone units, or they can be joined together to create continuous runs. The graphics below show the components required to install a typical run of MicroSquare gen 2 suspended fixtures. **IMPORTANT: Read all instructions before beginning installation. All mount brackets must be secured to wall structure (stud or cross-braces)**

MicroSquare gen 2 Endcap Kit(s)

- Endcap
- Joiner bracket
- 2x joiner aligners

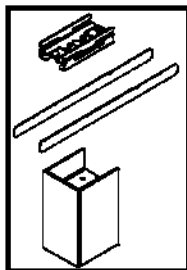

MicroSquare gen 2 Joint Kit(s)

- Joiner bracket
- 2x joiner aligner

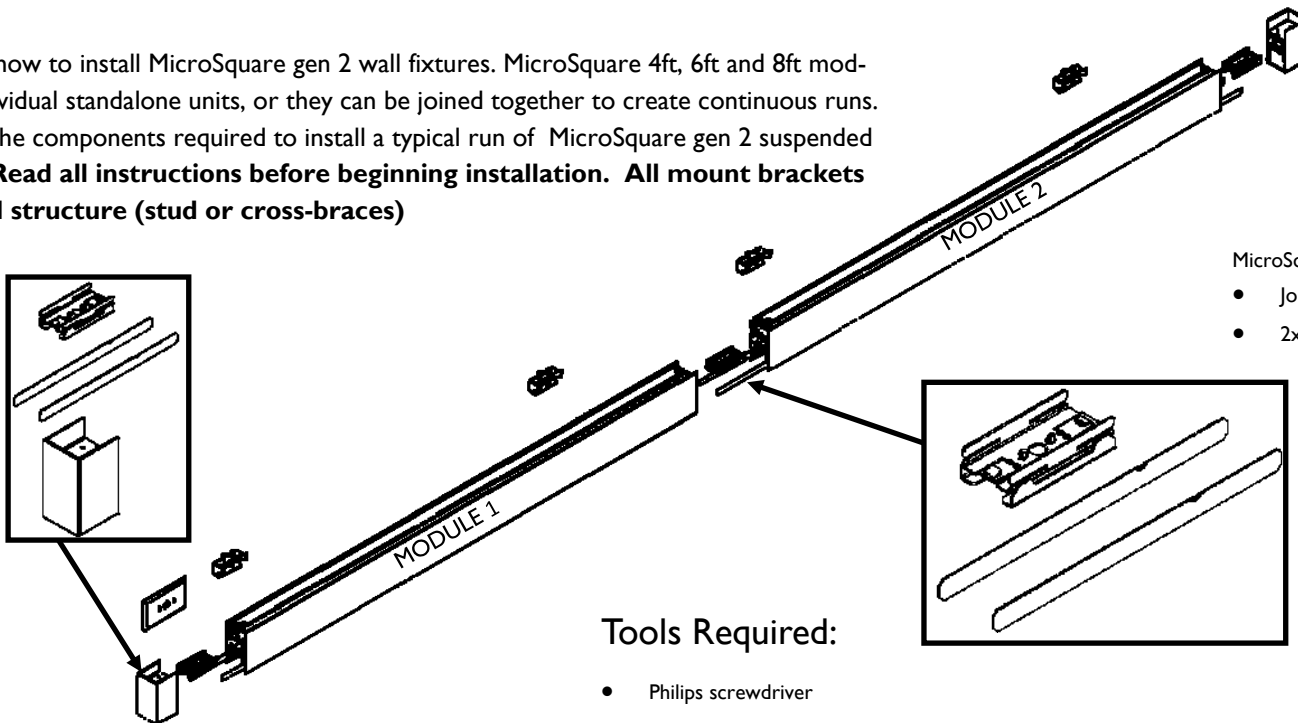
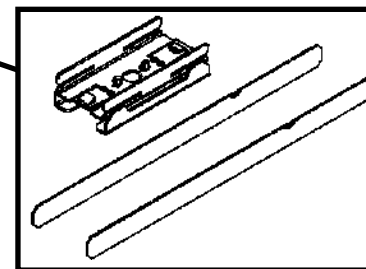

Tools Required:

- Philips screwdriver
- Flat head screwdriver

Module Lengths

MicroSquare suspended fixtures come in 4ft, 6ft and 8ft modules. Overall module lengths are shown below. Add 2.2" for each endcap for accurate run length.

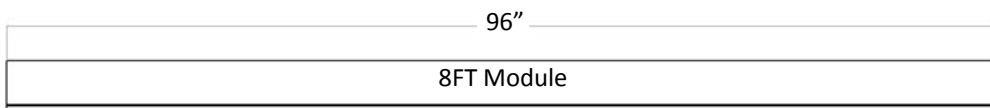
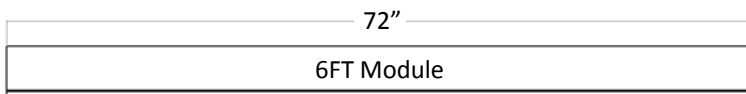
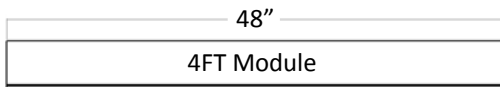

Mount Spacing

MicroSquare gen 2 wall fixture modules are designed to attach to supplied wall brackets. Use 2 brackets for each 4ft module and 3 brackets for each 6ft and 8ft modules. Brackets must be installed a minimum 12" away from fixture ends



! ATTENTION: Install in accordance with national and local building and electrical codes.

1 Arrange boxed fixture on floor in specified mounting location, remove fixtures from boxes. Install all ceiling mounting components and vertical aircraft cables using separate installation instruction for Aircraft Cable Mounting (supplied).

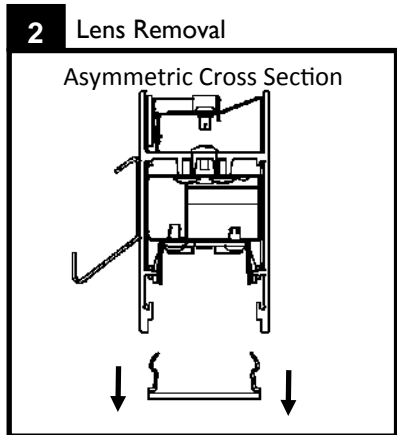

Remove lens from fixture and set aside until fixture installation is complete. Use cotton gloves to handle lenses and keep in a clean environment.

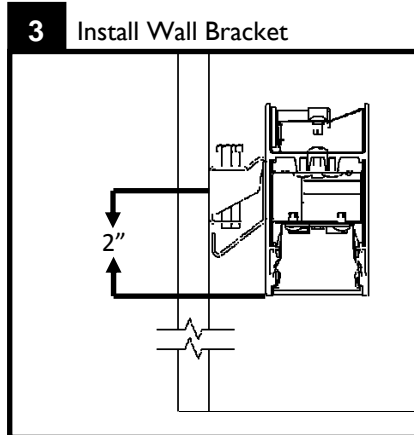

Determine above finished floor dimension and add 2" for indirect configuration. Draw center line, level and center wall brackets. Install to structure using appropriate hardware (by others).

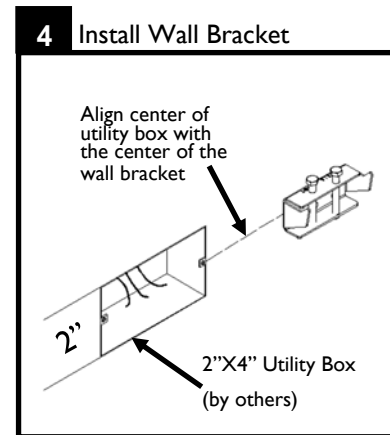

Determine power location for 2"X4" utility box (by others). Prior to installation, ensure center of utility box is centered on wall bracket center line as shown. Recommended position of utility box is 6" to 8" away from fixture end.

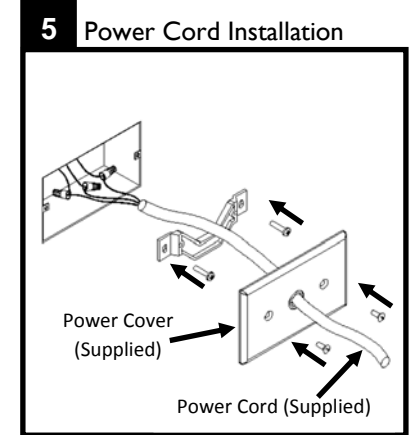

Complete wall power connections and attach supplied power cord through power cover. Attach cover to utility box.

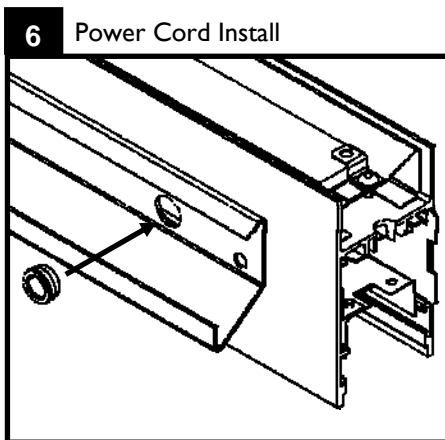

Determine power feed location on fixture. Attach supplied 1/2" bushing as shown.

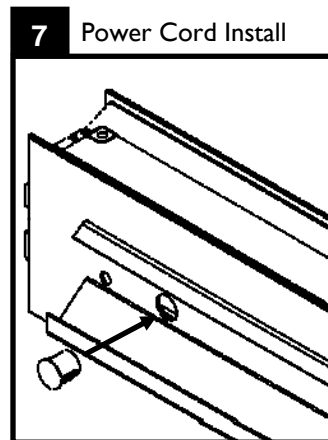

Install supplied 1/2" plug at opposite end of fixture housing.

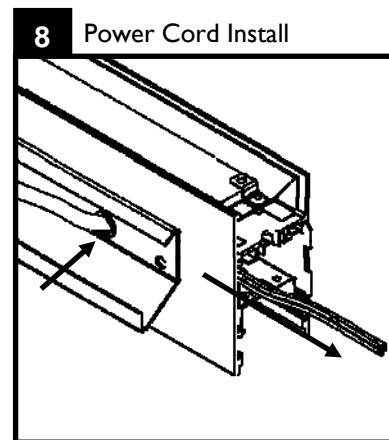

Pass power cord through bushing and out the end of the luminaire

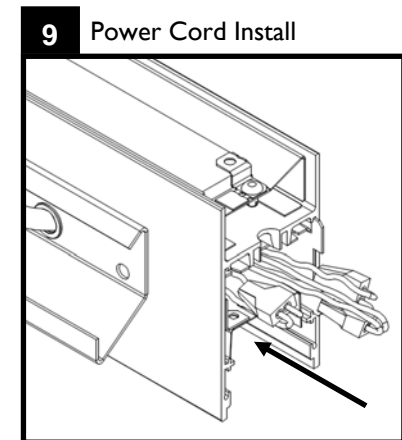

Connect power cord wires to corresponding power wires in luminaire

! ATTENTION: Install in accordance with national and local building and electrical codes.

10 Fixture Installation

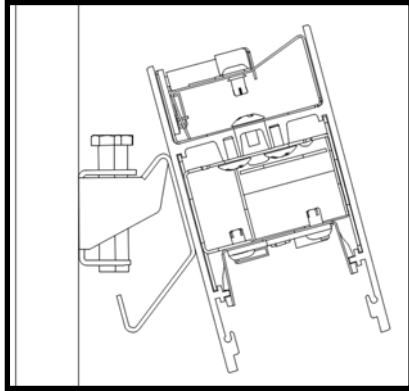

Hook fixture housing on top of wall bracket and gently rotate downwards while supporting housing. Housing should engage on all wall brackets and lock in position.

11 Fixture Installation

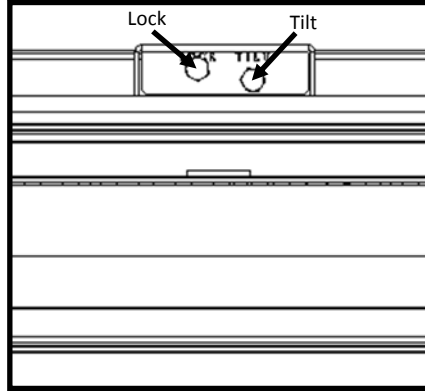

After module 1 is installed, adjust the tilt screw as required to level fixture.

12 Fixture Joining and Endcaps

- To join fixtures, follow attached MicroSquare gen 2 suspended installation instructions.

13 Finishing

- Ensure all fixtures are level and in line with each other.
- If horizontal leveling is required, adjust tilt screw shown in step 10, level fixture and re-tighten screw.
- Check that all joint or endcap screws are installed and all seams are tight.
- Use spare 1/2" plug(s) provided to close any open 1/2" electrical knockout location(s) in top reflector.
- Lock wall bracket screws shown in step 10 to secure fixtures to wall brackets.

14 Reinstall Lens and Endcap Plate

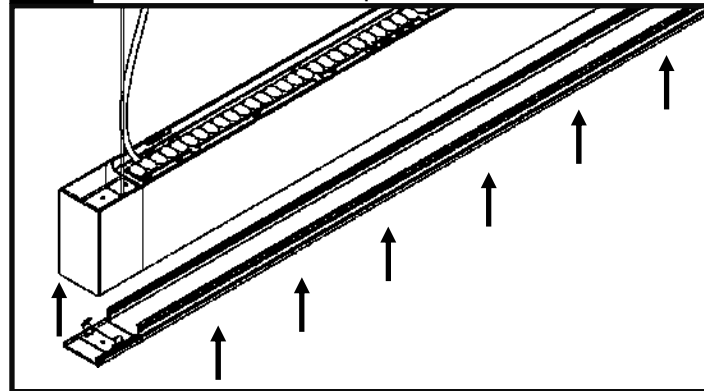

Reinstall the lens and Endcap plate.