

## System Overview

These instructions review how to install MicroSquare gen 2 suspended fixtures. MicroSquare 4ft, 6ft and 8ft modules can be installed as individual standalone units, or they can be joined together to create continuous runs. The graphics below show the components required to install a typical run of MicroSquare gen 2 suspended fixtures. **IMPORTANT: Read all instructions before beginning installation.**

### MicroSquare gen 2 Endcap Kit(s)

- Endcap
- Joiner bracket
- 2x joiner aligners

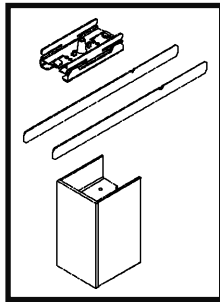

### MicroSquare gen 2 Joint Kit(s)

- Joiner bracket
- 2x joiner aligner

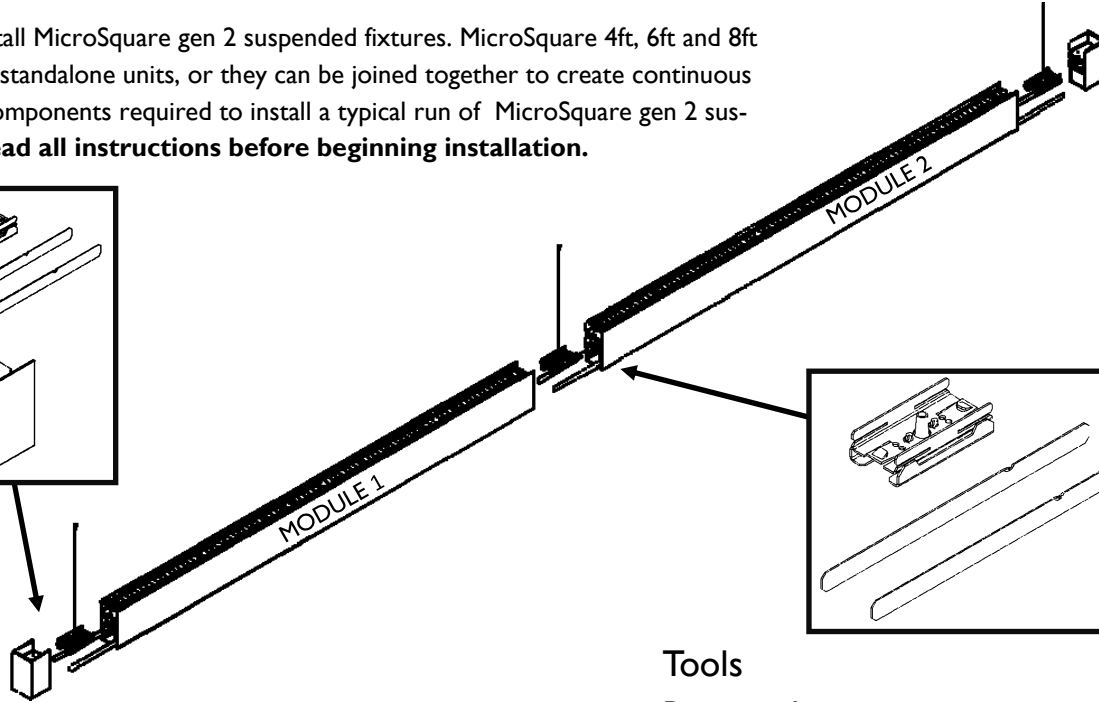
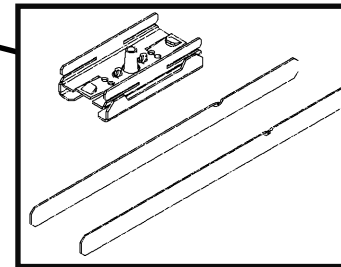

## Module Lengths

MicroSquare suspended fixtures come in 4ft, 6ft and 8ft modules. Overall module lengths are shown below. Add 2.2" for each endcap for accurate run length.

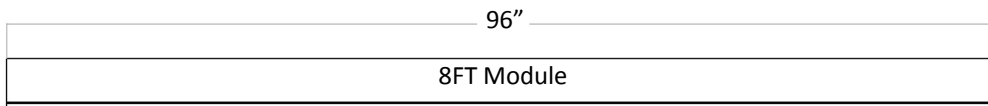
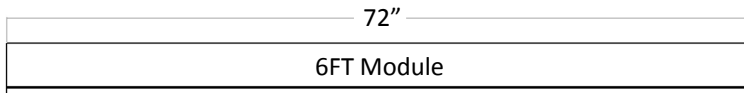
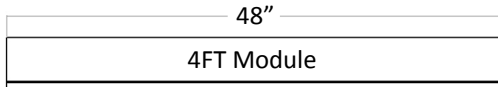

## Tools

### Required:

- Philips screwdriver

## Mount Spacing

MicroSquare gen 2 fixture modules are designed for exact on-grid mounting with mounts attached to the joiner assemblies.

**! ATTENTION: Install in accordance with national and local building and electrical codes.**

**1** Arrange boxed fixture on floor in specified mounting location, remove fixtures from boxes. Install all ceiling mounting components and vertical aircraft cables using separate installation instruction for Aircraft Cable Mounting (supplied).

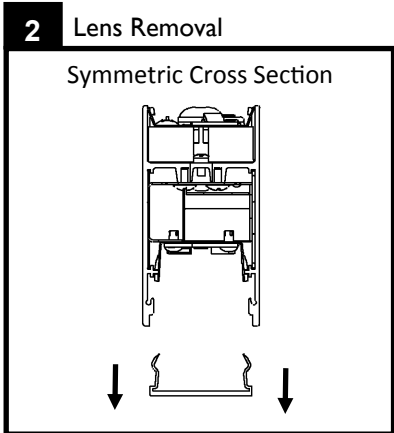

Remove lens from fixture and set aside until fixture installation is complete. Use cotton gloves to handle lenses and keep in a clean environment.

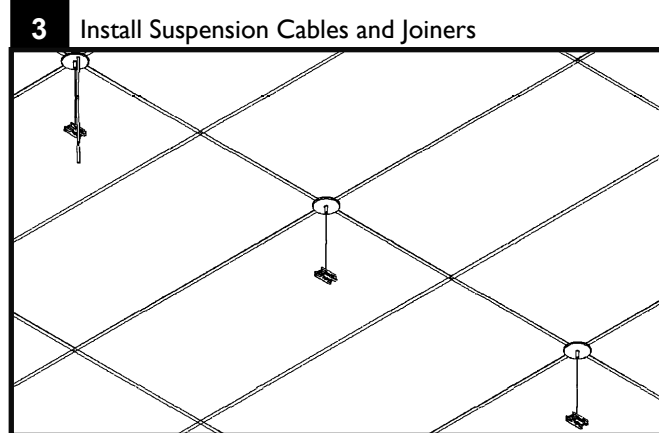

Hang joiner brackets at mounting locations. Bottom lens will be 1.9" (48mm) lower than the bottom of the mounting bracket. Assure that the brackets are at the desired height and trim aircraft cable to length.

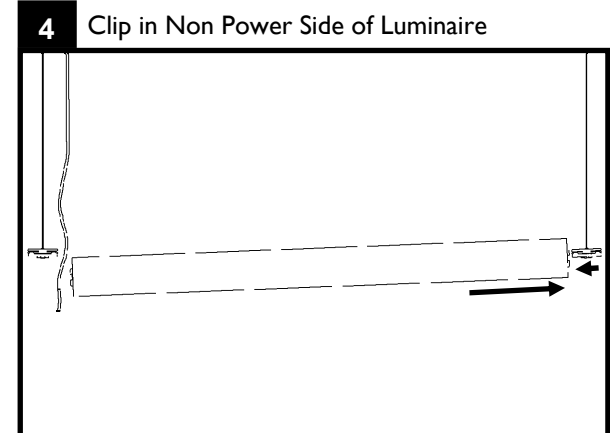

Clip in far side from power drop.

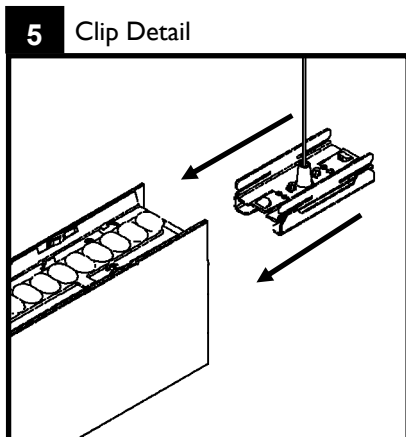

Insert joiner bracket squarely into sheet metal crossplate

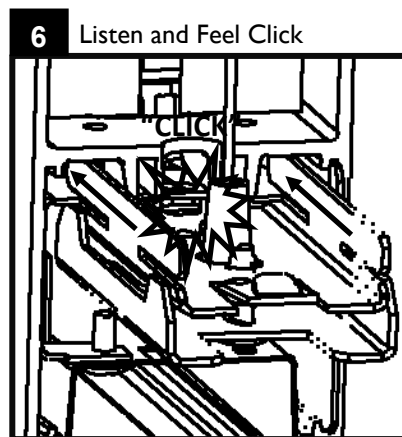

Top tabs of the joiner bracket should go between the extrusion and sheet metal crossplate. Joiner bracket should seat fully and an audible and tactile click should be heard.

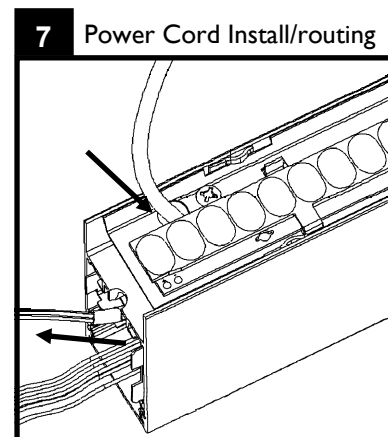

Feed power cable through knockout in the top of the luminaire and out the end of fixture. Add strain relief to power cord.

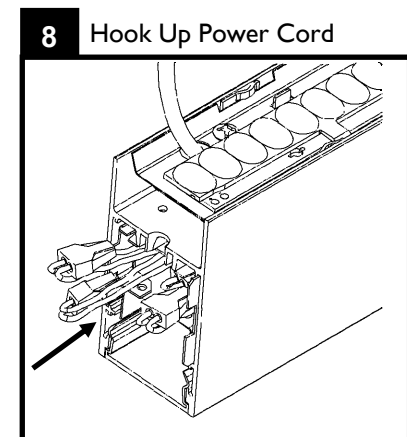

Connect power cable to through wiring already present in the luminaire. Once connected push wires at least 2" (50mm) into luminaire.

**!** **ATTENTION: Install in accordance with national and local building and electrical codes.**

9 Clip in Power Side of Luminaire

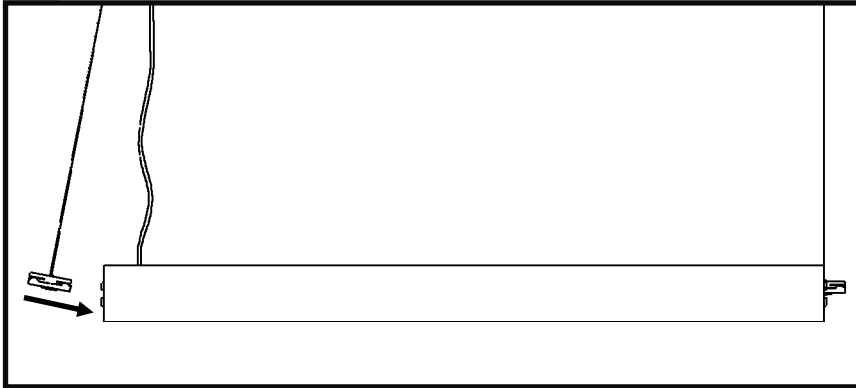

Slide joiner bracket into power entry side of the luminaire.

10 Listen and Feel Click

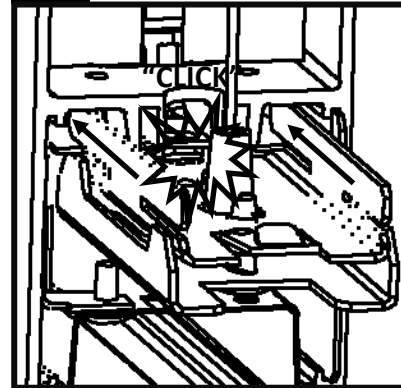

Top tabs of the joiner bracket should go between the extrusion and sheet metal cross plate. Joiner bracket should seat fully and an audible and tactile click should be heard.

12 Insert Aligning Tabs

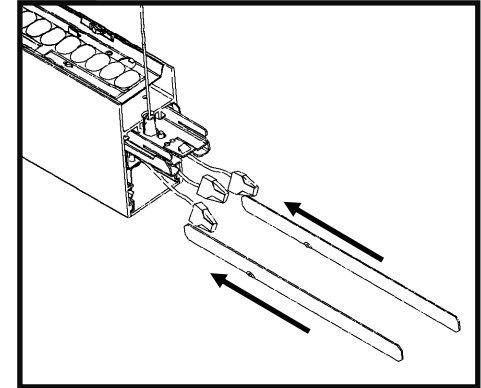

Slide joiner aligners into bottom extrusion detail. Ensure the small bump on the aligner is toward the lens. \*Note location of small bump should always be on the bottom

13 Click In Far End and Insert Aligning Tabs

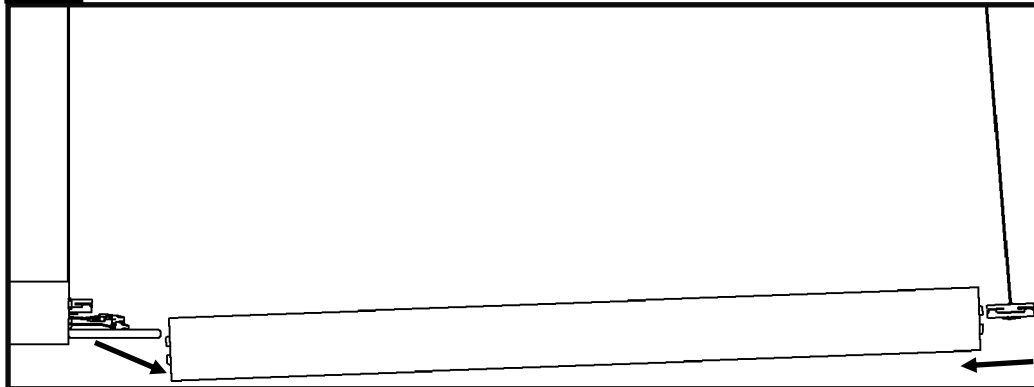

Slide joiner bracket into far side of the next luminaire in the row. Ensure that the bracket is fully seated and clicks into place. Slide luminaire onto aligner brackets of the previous luminaire.

12 Connect Power Wires

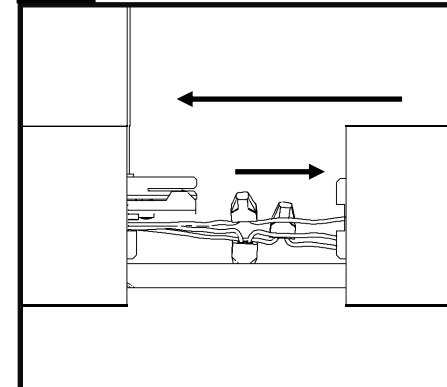

Connect wiring of adjacent luminaires. Once connected push wiring connectors at least 2" (50mm) into luminaire.

13 Listen For Click

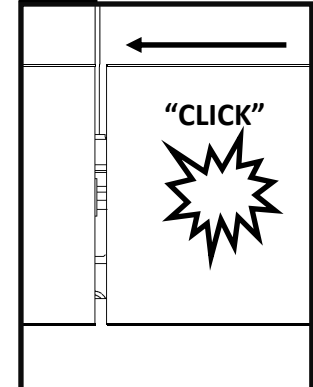

Push luminaires and together listen for a click as the joiner bracket is located.

14 Tighten Screws

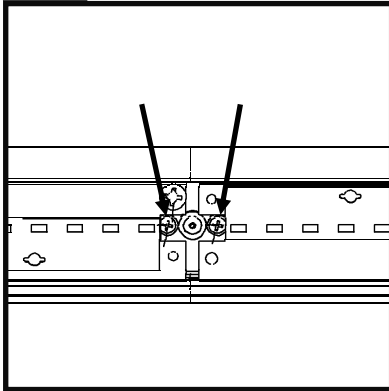

Tighten the screws alternating between the two.

15 Endcap Preparation

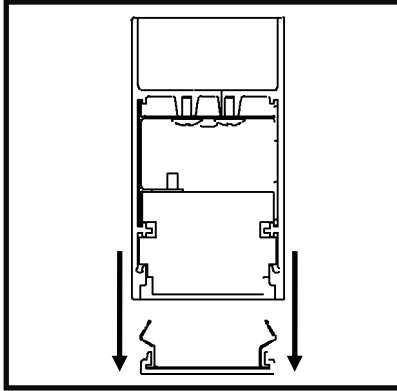

Remove the bottom cover from the endcap.

16 Install Endcap

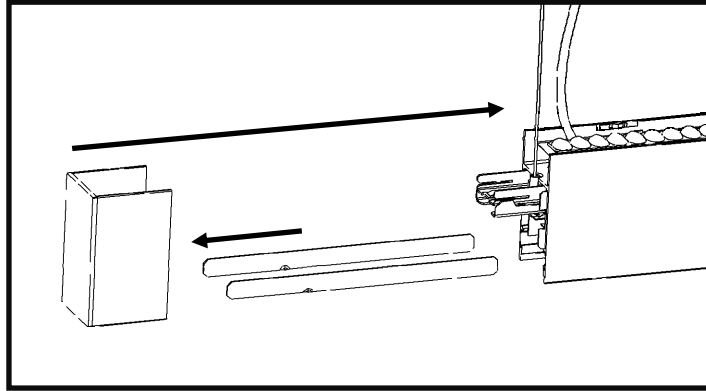

Install the joiner aligners making sure to keep the small tab toward the bottom. Slide the endcap over the joiners and onto the joiner bracket.

17 Listen For Click

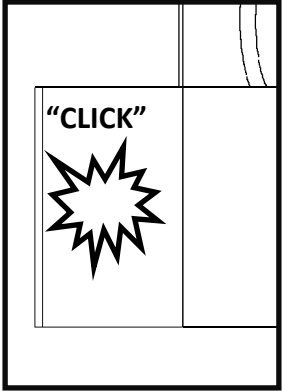

Listen for a click as the joiner bracket is located.

18 Tighten Screws

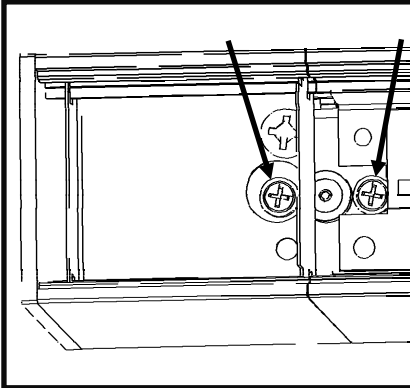

Tighten the screws alternating between the two.

19 Reinstall Lens and Endcap Plate

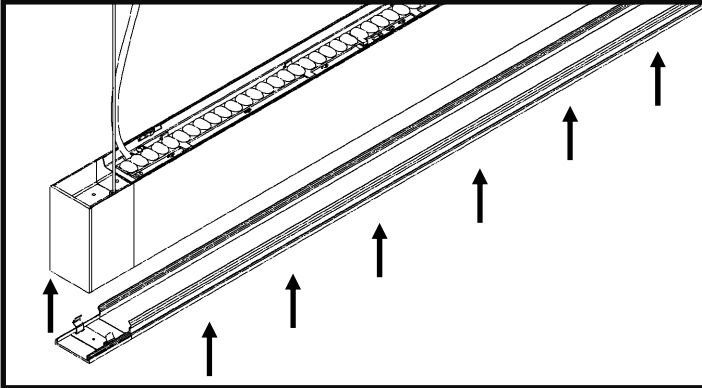

Reinstall the lens and Endcap plate.

**!** ATTENTION: Install in accordance with national and local building and electrical codes.