

System Overview

These instructions review how to install Voice wall mount fixtures. Voice 4ft and 8ft modules can be installed as individual standalone units, or they can be joined together to create continuous rows. The graphic below shows the components required to install a typical row of Voice wall mount fixtures.

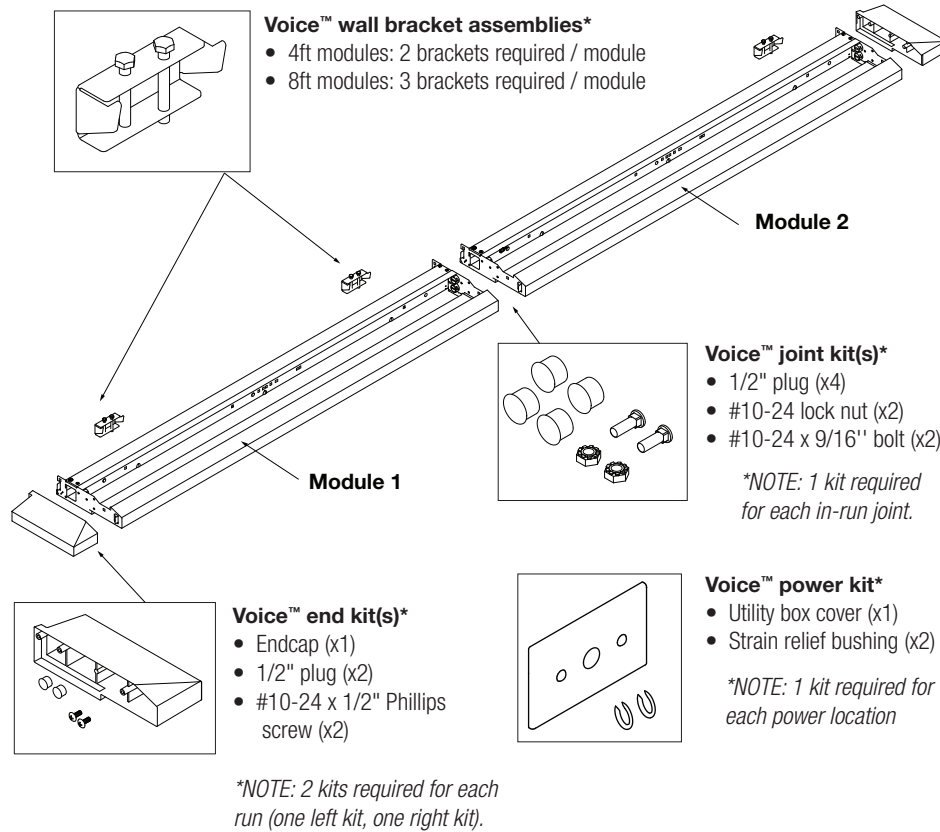

Module Lengths

Voice wall mount systems come in 4ft and 8ft modules. Overall module lengths are shown right. Module lengths do not include endcaps.

T5 lamp versions

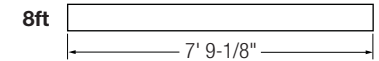
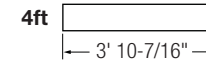

T8 lamp versions

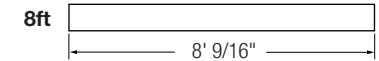
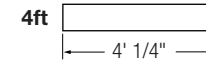

Indicates overall length of fixture (excluding endcaps)

Endcaps

Add two endcaps to the length of each row (left and right endcaps supplied).

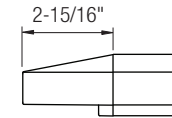

Mount Spacing

- Mounts can be positioned anywhere along the length of the fixture within 12" from ends.
- On 8ft modules, maximum distance between mounts is 48"

Row Configurations

The table indicates how nominal 4ft and 8ft modules can be combined to create continuous rows of various lengths. Modules can be combined in any order.

Nominal Row Length	Number of modules required	
	4ft module	8ft module
4'	1x	
8'		1x
12'	1x	1x
16'		2x
20'	1x	2x
24'		3x
28'	1x	3x
32'		4x



ATTENTION: Install in accordance with national and local building and electrical codes.

! IMPORTANT

IMPORTANT: Read all instructions at least once prior to beginning installation.

All wall brackets must be installed within 12" of fixture ends and must be secured to wall structure (eg. studs or cross-braces).

All utility boxes must be installed within 18" of fixture ends.

Please see step 1 and 2 for vertical positioning of wall brackets and utility boxes on wall.

1 Install wall brackets

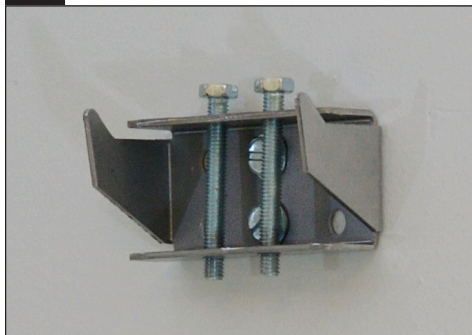

Determine required fixture mounting location measurement from finished floor. Mark bottom edge of fixture with a reference line. Position bottom edge of wall brackets 1/2" above reference line and secure using appropriate fasteners (two per bracket, supplied by others).

Note: Bottom of wall brackets must be 1/2" higher than bottom of fixture.

2 Install utility box and utility box cover

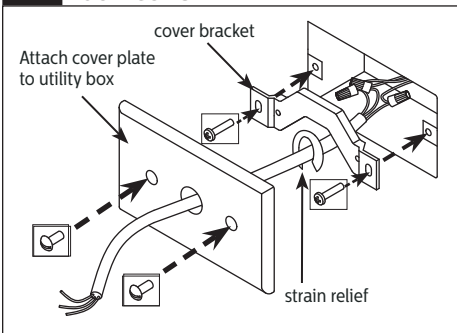

Determine required fixture mounting location measurement from finished floor. Mark bottom edge of fixture with a reference line. Position center line of side mounted 2x4 utility box 2" above reference line and complete installation. Complete power connections inside utility box. Attach cover bracket using supplied hardware. Punch power access hole in cover, feed power cord through and attach strain relief on wall side. Attach cover using supplied painted hardware.

TIP: Center of utility box and cover should be in line with top edge of fixture.

3 Unpack / prepare fixtures

Arrange boxed fixtures on floor in specified mounting locations; remove fixtures from boxes; remove plastic from fixtures. Cap all unnecessary power feed holes at back of fixture(s) using supplied 1/2" plugs.

4 Raise fixture and engage on wall brackets

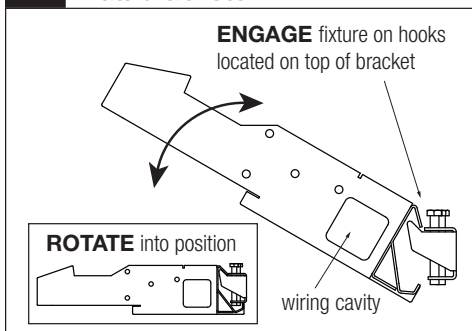

Raise fixture and engage it on hooks located on top of wall brackets, then rotate it down into position. **POWER LOCATIONS:** Feed installed power cord through the 1/2" access hole at back of fixture and through wiring cavity at end of fixture prior to engaging fixture on wall brackets.

5 Access wiring / remove reflector



If access to wiring inside fixture is required, remove hardware (4 Phillips screws), lift and rotate reflector (shown right).

6 Complete electrical connections



At end of fixture, complete electrical connections using wire nuts (supplied by others). If required, re-install reflector and hardware removed in STEP 5.



ATTENTION: Install in accordance with national and local building and electrical codes.

7 Level and secure first fixture using TILT and LOCK adjustments

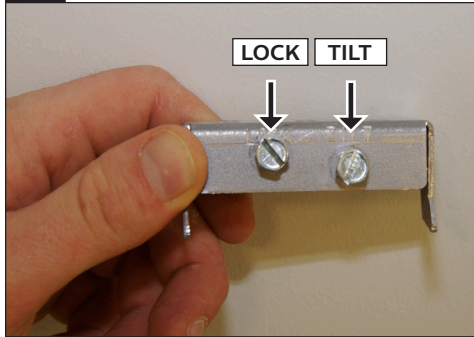

LEVEL: Using a 5/16" hex nut driver, level fixture by adjusting the TILT screw. **SECURE:** Secure fixture to wall bracket assemblies by tightening the LOCK screw.

TOOLS: Requires 5/16" hex nut driver

8 Install and join additional fixtures to create row

Raise next fixture and engage on mounting brackets (see STEP 4). Complete electrical connections between fixtures using supplied quick-wire connectors and tuck wires into wiring cavity. Level second fixture by adjusting the TILT screw (see STEP 7). Slide second fixture flush against first fixture and secure joint using supplied nut and bolt hardware (requires 3/8" nut driver). Secure fixture to wall brackets by tightening the LOCK screw at each bracket location (see STEP 7).

Repeat STEP 8 for each additional fixture(s) in row.

IMPORTANT: Do not attempt to join fixtures on floor. Instead, mount one fixture at a time and join modules at wall level.

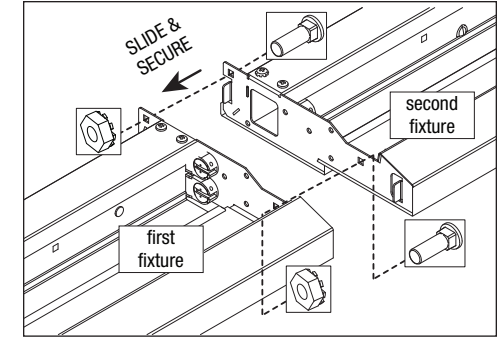

IMPORTANT: Ledalite recommends tightening fasteners by hand. When joining modules, ensure nut is tightened snug plus an additional 1/4 turn.

9 Install endcaps



Attach left and right endcaps to first and last module in each row using supplied hardware.

TOOLS: Requires Phillips screwdriver.

10 Finishing

Lamp fixtures

Secure components: Tighten screws at all joints and bracket locations.



ATTENTION: Install in accordance with national and local building and electrical codes.