

Power Feed

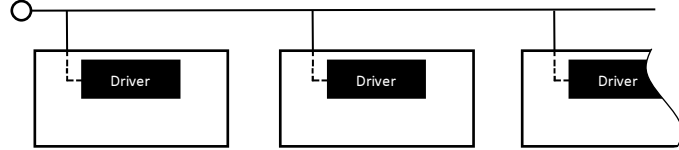

Every fixture contains its own driver and receives a direct power feed.

1 Bend mounting tab

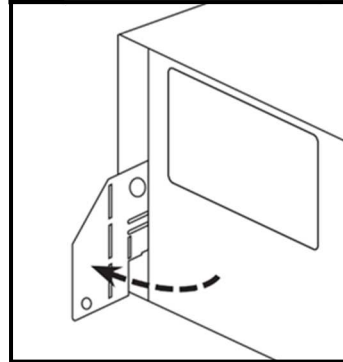

Bend out mounting tab 90 degrees on each corner.

2 Adjust height of tab

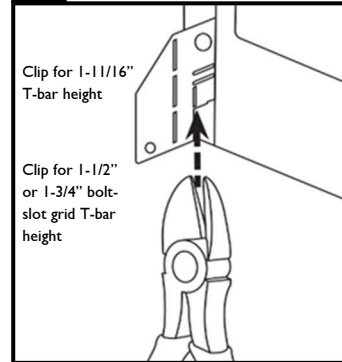

Use side cutters to adjust each tab to height of T-grid.

3 Lay fixture into T-grid

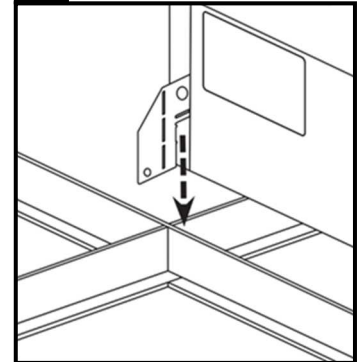

Lay fixture into T-grid.

4 Bend tabs flush

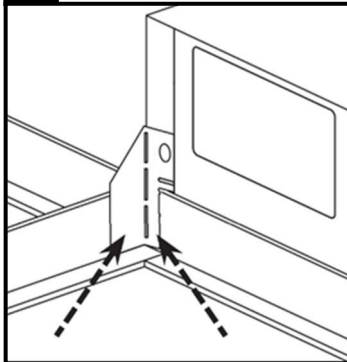

Bend tabs flush against T-grid in order to clear for ceiling tile.

5 Fasten fixture to T-grid

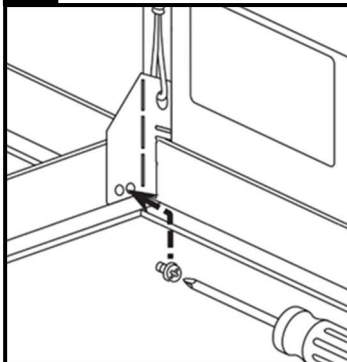

Use a #8x1/4" sheet metal screw to fasten fixture to T-grid and use a hanger wire to tie off appropriately in accordance with the local building codes (screws and hanger wires supplied by others).

6 Electrical connections

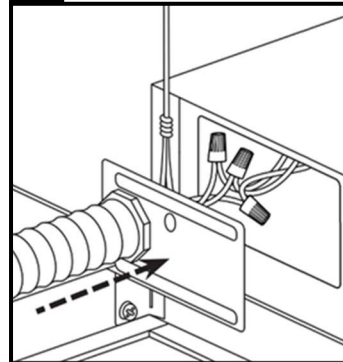

Make all electrical connections to the fixture.

Note: For flex whip option, see Step 6a.

6a Flex whip (optional)

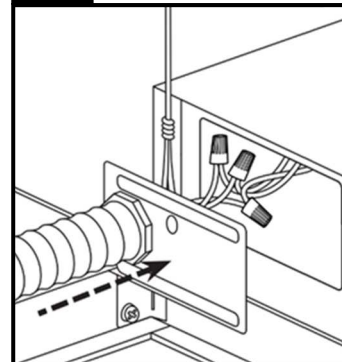

Optional Flex whip is prewired inside fixture. Remove packaging and insert snap-in fitting into wiring cover. Complete electrical connections at other end of whip in accordance with local building codes.

7 Filler panels (20"x4' only)

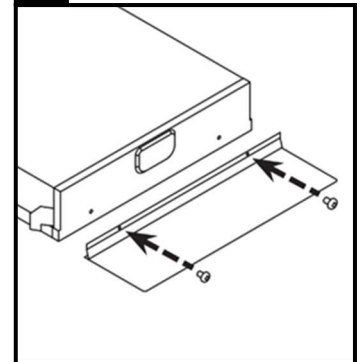

Attach filler panels to ends of housing using two supplied screws shown above.

! ATTENTION: Install in accordance with national and local building and electrical codes.